

## RCC32-E32T

### Features

- > Type-A+6mA residual current module for EV charging pile protection
- > Mounted on PCB board
- > Dual digital open-drain output,20mAAC/6mADC trip indication
- > 3-phase primary conductors on module (typ.32A,max.40A)
- > PWM output for DC residual current value indication (0~30mA)
- > Error output for system fault indication
- > High-frequency response up to 2kHz

### Standard

- > Meets the requirements of GB/T 40820 (IEC 62955) for the residual current operation characteristics of the mode three charge RDC-PD
- > Meets the basic residual current operating characteristics requirements of GB/T 22794 (IEC 62423) and adapts to DC 6mA test requirements

#### Trip-Current (residual current related characteristics)

Wav.	Freq.	Min.	Typ.	Max.	Unit
AC	50Hz	20.0	23.0	26.0	mA
A0	50Hz	11.0	19.0	30.0	mA
A90	50Hz	10.0	24.0	30.0	mA
A135	50Hz	10.0	28.0	35.0	mA
2PDC	50Hz	3.5	5.2	7.0	mA
3PDC	50Hz	3.1	4.6	6.2	mA
S-DC	-	3.0	4.6	6.0	mA

#### Trip-Time (residual current related characteristics)

Wav.	Freq.	Current	Typ.	Unit
AC	50Hz	30mA	115.0	ms
AC	50Hz	60mA	50.0	ms
AC	50Hz	150mA	15.0	ms
AC	50Hz	5A~100A	8.5	ms
A0	50Hz	42mA	35.0	ms
A0	50Hz	84mA	30.0	ms
A0	50Hz	350mA	15.0	ms
A0	50Hz	42mA+6mADC	45.0	ms
A0	50Hz	84mA+6mADC	20.0	ms
A0	50Hz	350mA+6mADC	15.0	ms
2PDC/3PDC	50Hz	60mA	40.0	ms
2PDC/3PDC	50Hz	120mA	15.0	ms
2PDC/3PDC	50Hz	300mA	15.0	ms
2PDC/3PDC	50Hz	5A~50A	10.0	ms
S-DC	-	6mA	140.0	ms.
S-DC	-	60mA	45.0	ms
S-DC	-	300mA	10.0	ms

#### Electrical & Reliability Parameters

Char.	Value
Working Temperature	-40°C~105°C
Storage Temperature	-40°C~105°C
Supply Voltage (VDD) <sup>(1)</sup>	4.85~5.15 VDC
Static Power Consumption	≤ 110 mW
Clearance	≥ 5.6 mm
(Primary-Primary/Secondary)	≥ 10.0 mm
Creepage	≥ 8.0 mm
(Primary-Primary/Secondary)	≥ 10.0 mm
Voltage Input,low level	0~0.6 VDC
Voltage Input,high level	4.2~5 VDC
FIT <sup>(2)</sup>	Please contact us
Designed Life <sup>(3)</sup>	≥ 20 years
Working Altitude <sup>(4)</sup>	≤ 4000m

<sup>(1)</sup> It is suggested to control VDD within 4.9~5.1 VDC to get better performance

<sup>(2)</sup> The calculation of FIT according to IEC 61709, is based on the FIT values of different different components in the BoM list. And the calculation principle: ground mobile, no dust or harmful substances

<sup>(3)</sup> The calculation and claim of product life is based on the MTBF value according to IEC 61709

<sup>(4)</sup> The calculation about altitude is based on the principles: reinforced insulation, insulation material group 3, pollution degree 2, overvoltage category 3

## Typical Application Schematic &amp; Pin Definition

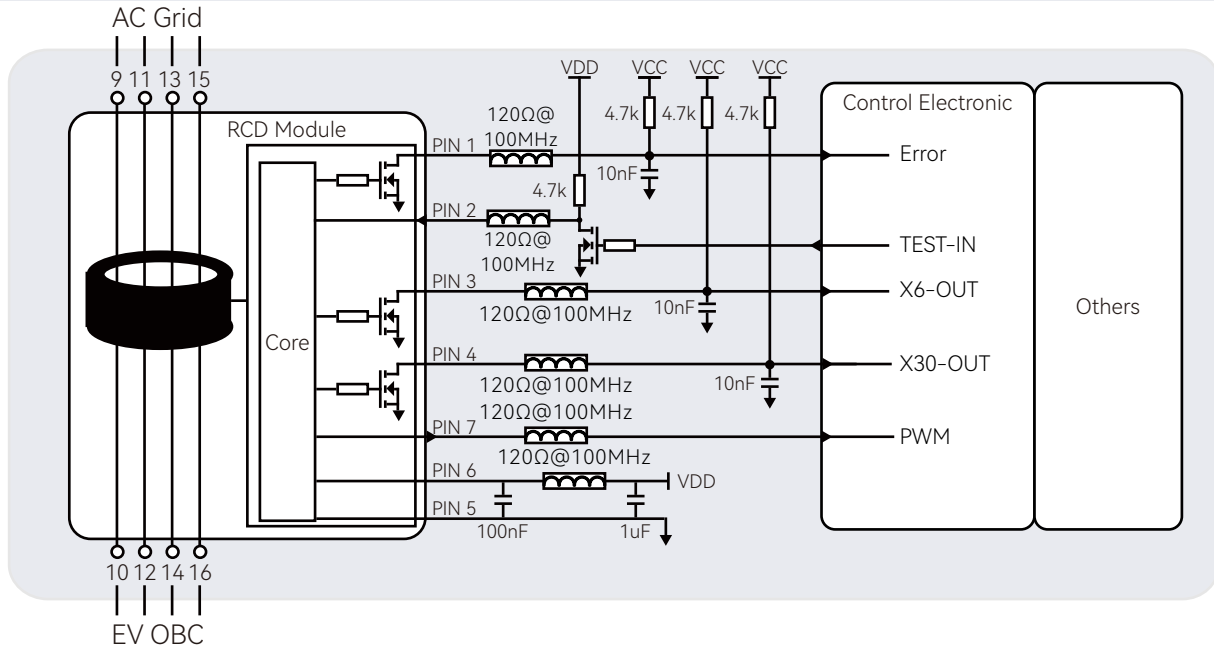

Pin-No.	Pin Name	Function
PIN-1	Error	<ul style="list-style-type: none"> <li>&gt; Open-drain output pin for indicating the system fault condition</li> <li>&gt; When no system fault, this pin will be conducted to GND</li> <li>&gt; When system fault occurred, this pin will be high-impedance</li> <li>&gt; It is recommended that the PIN pin add beads and place them close to the pins</li> </ul>
PIN-2	TEST-IN	<ul style="list-style-type: none"> <li>&gt; When this pin been conducted to 0 VDC, module will calculate the zero-point-drift and store the value to register in the MCU to finish the calibration operation</li> <li>&gt; After calibration finished, system will internally generate simulated residual current, to check whether module can do the correct response. During this procedure, X30-OUT &amp; X6-OUT will turn to high-impedance if module working correct</li> <li>&gt; It is recommended that the PIN pin add beads and 1nF capacitance to ground and be placed close to the pins</li> </ul> <p>Attention:</p> <ul style="list-style-type: none"> <li>&gt; When using the TEST-IN function, the main circuit must be cut-off to ensure no residual current flowing</li> <li>&gt; When using this pin function, please follow the timing diagram figure</li> </ul>
PIN-3	X6-OUT	<ul style="list-style-type: none"> <li>&gt; This output is in a high state (including during self-test) if the residual current exceeds the preset DC trip value (typically 4.6 mADC for this module)</li> <li>&gt; For other conditions, this output is low (GND)</li> <li>&gt; It is recommended that the PIN pin add beads and place them close to the pins</li> </ul>
PIN-4	X30-OUT	<ul style="list-style-type: none"> <li>&gt; This output can only be in a high-impedance state during a well-functioning self-test of the module</li> <li>&gt; For other conditions, this output is low (GND)</li> <li>&gt; It is recommended that the PIN pin add beads and place them close to the pins</li> </ul>
PIN-5	GND	<ul style="list-style-type: none"> <li>&gt; Product power grounding pins</li> </ul>
PIN-6	VDD	<ul style="list-style-type: none"> <li>&gt; The product power supply pins, standard supply voltage 5 VDC</li> <li>&gt; The input voltage range is required to be 4.85~5.15 VDC, and the power output capability is &gt; 100mA</li> <li>&gt; Power supply ripple ≤ 150mV (LDO circuit recommended, refer to power chip LP2985A-50DB)</li> </ul>
PIN-7	PWM	<ul style="list-style-type: none"> <li>&gt; It is recommended that the PIN pin add beads and place them close to the pins</li> <li>&gt; indicates the residual current component with duty cycle and has 8kHz PWM</li> <li>&gt; Output resolution = 3.33% mADC, 0~30mADC; Accuracy of about ± 0.5mA</li> <li>&gt; It is recommended that the PIN pin add beads and place them close to the pins</li> </ul>
PIN-8	N.C.	<ul style="list-style-type: none"> <li>&gt; Unused</li> </ul>
PIN-9,11,13,15	AC Primary	<ul style="list-style-type: none"> <li>&gt; All 4 PINs AC in together or AC out together</li> </ul>
PIN-10,12,14,16	AC Primary	<ul style="list-style-type: none"> <li>&gt; All 4 PINs AC in together or AC out together</li> </ul>

## Mechanical dimensions

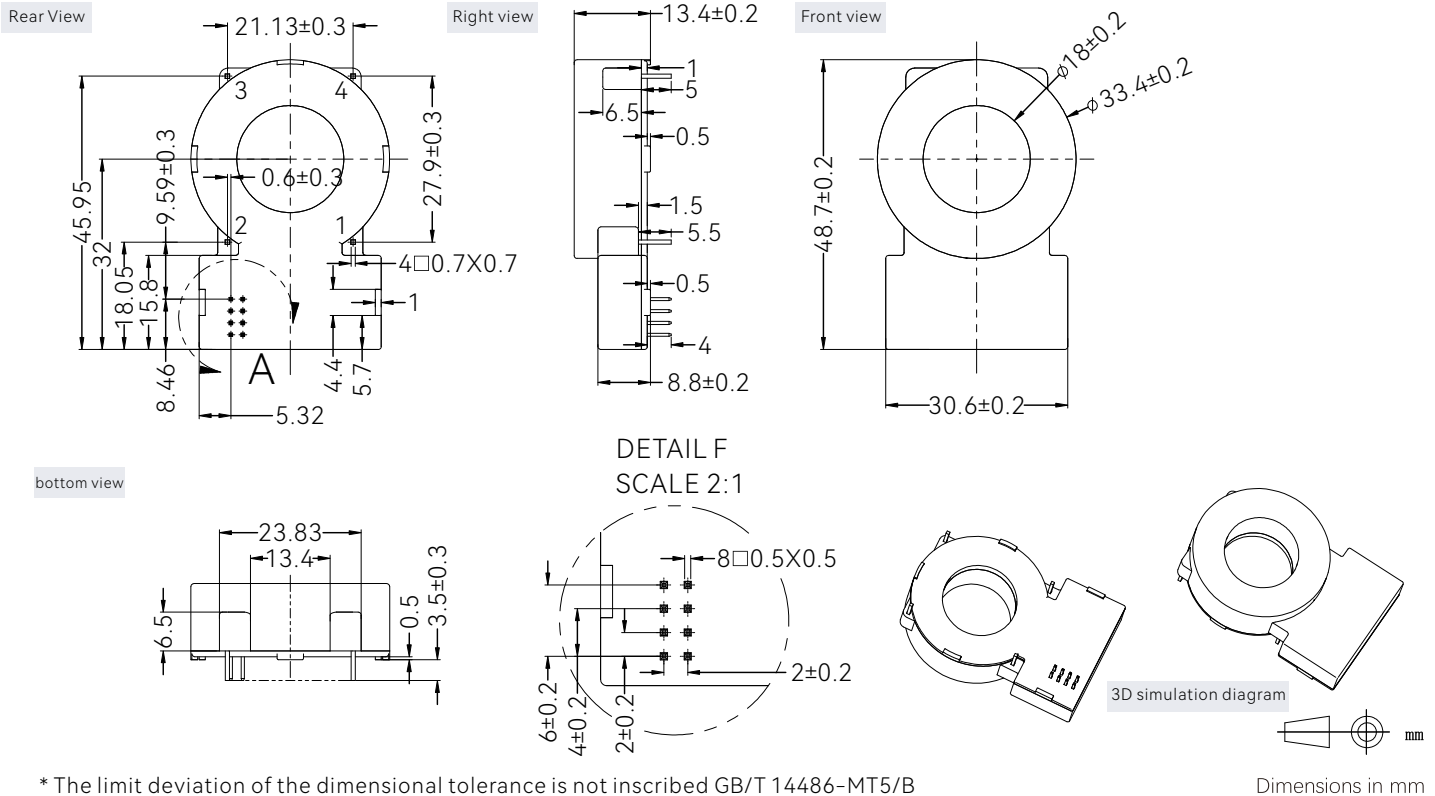

## TEST-IN timing diagram

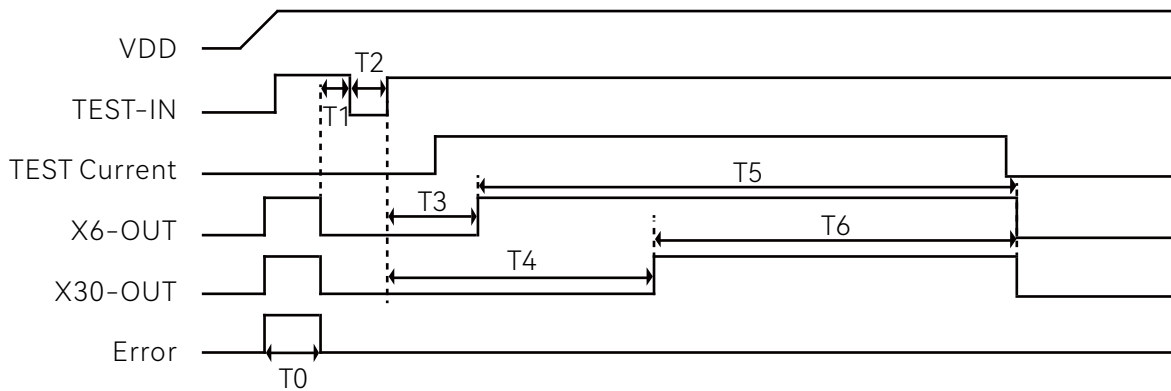

- > Suggest starting VDD from 0V, with a monotonous power on process and a time of <math><15\text{ms}</math>
- > T0 as the waiting time for system stability,  $T0 \approx 270\text{ms}$
- > The VDD establishment time should be  $\leq 3\text{ms/V}$ , i.e.  $\leq 15\text{ms}$  to establish a stable 5V
- > T1 is the waiting time after powering on, it is recommended that  $T1 \geq 100\text{ms}$
- > T2 is the system self check and internal calibration command. It is recommended that  $50\text{ms} \leq T2 \leq 100\text{ms}$ . When the low level of the pin exceeds 50ms, the product begins to enter self check testing
- > T3 is the waiting time for calibration completion,  $T3 \approx 300\text{ms}$ . It is recommended to read X6 OUT after 300ms
- > T4 is the enabling time of the self check signal,  $T4 \approx 700\text{ms}$ . It is recommended to read X30-OUT after 300ms
- > T5 is the delay time of the action signal,  $T5 \approx 1480\text{ms}$
- > T6 is the maintenance time of the action signal after the self check is completed,  $T6 \approx 1080\text{ms}$

Attention: During the self check process, the main circuit must be cut off to ensure that there is no residual current flowing. After the X6-OUT and X30-OUT self checks are completed, the normal residual current trip logic can be activated

## Digital Signal Flip Threshold

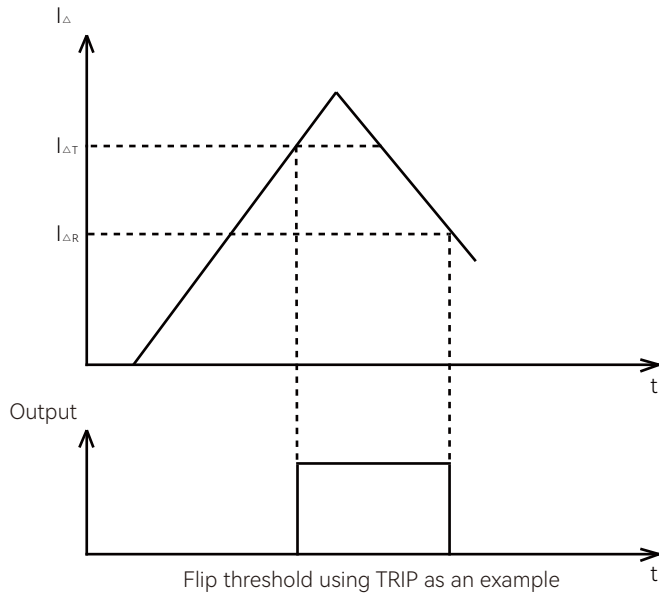

- > For avoiding the signal oscillation, tripping signal output flipping has been set with tripping threshold and recovery threshold
- > When tripping threshold  $I_{\Delta T}$  reached, the related X-OUT flip, and when the current decrease to the recovery threshold  $I_{\Delta R}$ , the related X-OUT flip again, back to low level state
- >  $I_{\Delta T}$  is set as 100% typical tripping value, and  $I_{\Delta R}$  is set as 55% typical tripping value

## Self-Test Circuit

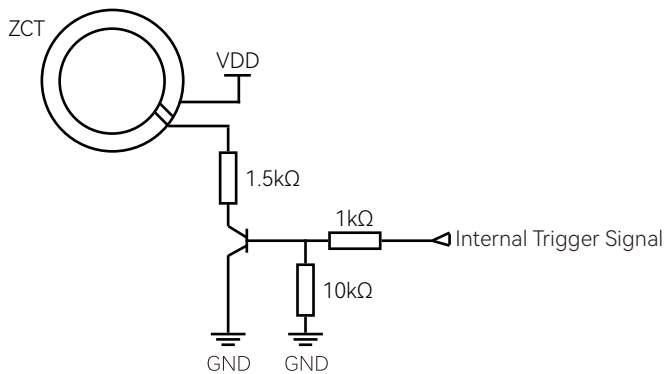

- > 2 winding on the ZCT to generate simulated DC residual current
- > By using VDD to generate typical value = 6.53 mADC simulated residual current
- > Use the most stringent 6mADC value to detect whether the module can work properly and identify residual current

## Version history

Version number	Modifications	Reason for modification
V1.3.6	Update the product dimension drawing	Erratum
V1.3.7	Update the product feature parameters	Erratum
V1.3.8	Update the product feature parameters	Erratum
V1.3.9	Update the product feature parameters	Update
V1.4.0	The UI of the product specification has been upgraded	

Note: Product data sheets may be updated without notice due to testing or design changes, please contact us for the most current version of the document.